



POOL HEATING & COOLING





POOL HEATING & COOLING

Electrical Heaters	347
Heat Exchanger	351
Heat & Chill Pumps	354
Inverter Heat & Chill Pump	368
Water to water Heat Pump	380
Residential Heat Pump with water tank	382
High Temperature Heat Pump	384
Dehumidifier	389



Pool Heating



► Proteam Europa - Plate Type Heat Exchangers

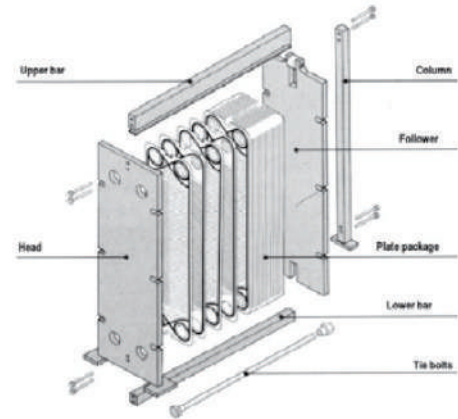
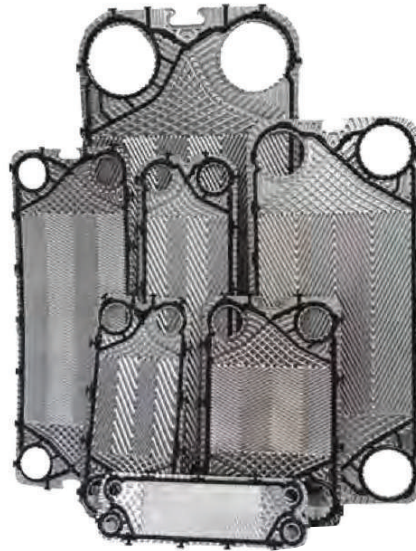

Specification

PROTEAM EUROPA heat exchangers offer plate type heat exchangers, copper brazed, semi-welded, all welded plate heat exchangers and freshwater generators. With the big range of plate type heat exchangers PROTEAM EUROPA has got the optimal technical solution for any possible task, with connection sizes from 15mm - 500mm covering a liquid flow of 50L/hours - 2000 m³/hour.

Plate Design

The construction of the inlet part makes a perfect distribution of the liquids across the heating surface. The inlet part is increased and supplied with grooves preventing “dead spots” which may cause the growth of bacteria in the plate heat exchanger. The inlet with grooves secures a strong inlet part with a minimum of contact points. The inlet parts are constructed with a leakage drained zone fulfilling the AAA specifications. The heat transfer plates are designed with a gap between plates up to 11mm depending on the plate type. Because the pattern of the plate pressing is horizontal waves maintaining no “plate contact points” in the flow direction, the flow channels remain free of obstacles allowing the media/particles to flow freely.

Edge Reinforcement

In order to strengthen the gasket groove PROTEAM EUROPA “Flex Line” is supplied with deep step edged grooves giving a perfect hold of the gasket. This means a long durability for gaskets as well as for plates.

The Gasketed plate Heat Exchanger The gasket is placed in the total protected gasket groove. This construction secures the elasticity of the gasket even after long time of assembling. The new generation of PROTEAM EUROPA plate heat exchangers is developed with the glueless “Lock” gasket. The “Lock” gasket is fixed by strong rubber button which contrary to most glueless gaskets of today reality fix the gasket in the groove.

Gasketed plate heat exchangers are applicable in many areas for heating/cooling i.e. in the food industry, the chemical area, by heat recovery, in HVAC units and many other areas. Pressure rating up to 25 bar Temperature up to 200°C

Pool Heating



Pool Heating



► Proteam Europa - Plate Type Heat Exchangers



Features

High Operation safety | Exact energy-transfer | Low running costs | Energy saving | Environment-friendly
Note Please ask for selection of Heat Exchanger for your pool. Selection chart/datasheet on request.

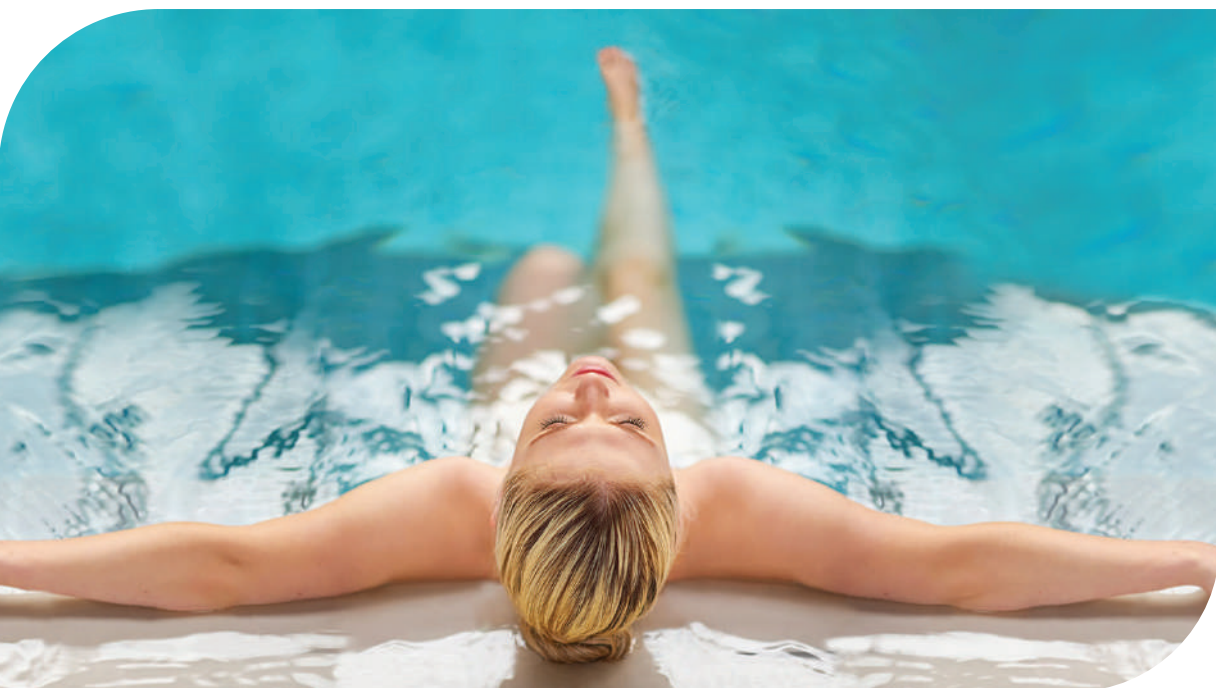

Pool Heating





HEAT AND CHILL PUMP



Control your pool temperature with mobile app

Pool Heating



► Heat and Chill Pump



Heat and Chill Pump

PROTEAM Europa Heat and Chill pump can be used for heating or cooling swimming pool, spa or some other open water system. The heat and chill pump manufactured very highest international standard quality with advanced technologies to maximize the performance and minimize the consumption. In consideration of this, PROTEAM heat pumps have always been specifically designed to have higher COP at lower temperature when maximum energy is needed. All PROTEAM heat pumps will be available with environmentally friendly refrigerant.

How Do Heat Pump Works

PROTEAM Europa Heat pump and chill pump principle Heat pumps function like a reversed air conditioning cooling system. The heat pump fan draws ambient air through the outer evaporator air coil that acts as a heat collector. The air coil has a liquid refrigerant which absorbs available heat in the passing air transforming it into a gas which is compressed by a compressor. When the gas is compressed it intensifies and concentrates the heat. This intense hot gas is then pumped in to the heat exchange condenser where the actual heat exchange takes place. As the pool water passes through the heat exchanger, the hot gas gives up its heat to the cooler pool water. Uses freely available air energy 4-5 times more effectively than conventional electrical heaters. If heat energy is converted to KW you get 4-5 kW of heating/cooling output. For every KW of power consumed, you get at least 4-5KW of free power.

Pool Heating

Highly Efficiency

Adopt heat pump for heating and the energy comes from ambient air. So its COP can reach 4.0 - 5.0. 70% can be saved compared with normal electrical heater.

Safety

Water and electricity are completely separate. ECO friendly gas, no fire, no electricity leakage, safer than fuel burner or electrical heater.

Environmentally Friendly

Adopt R407-C, R410-A, R134-A, R22 as refrigerant according to the requirements of EU Montreal protocol.

Long life Running

Titanium heat exchanger in PVC shell makes it super strong and resistant against erosion caused by chlorine and salt. SS316 casing for titanium heat exchanger is an option.



Pool Heating



► Heat and Chill Pump



Compressor

We use the reliable COPELAND scroll compressor. The simple design is with very few moving parts that enable it to operate at lower sound and vibration levels than reciprocating compressors. Test has shown that scroll compressors are up to three times quieter than other models. Millions of air conditioner around the world using Copeland scroll compressors is testimony to its quality and efficiency.

Water Heat Exchanger

This is made of double spiraled titanium tubes encased in PVC for additional protection against corrosive pool water. Titanium heat exchangers are superior to stainless steel and make the heat pump more efficiency and cost effective. The double spiraling of the heat exchanger increase the surface area that comes in contact with the pool water and also drastically reduces scaling

External Heat Exchanger

The tubes are made of copper and the fins in aluminium. The extra-large evaporator coils are designed to collect more heat from the outside air to ensure performance in even the most adverse conditions.

Pool Heating



Pool Heating



► Heat and Chill Pump



External Heat Exchanger

The tubes are made of copper and the fins in aluminium. The extra-large evaporator coils are designed to collect more heat from the outside air to ensure performance in even the most adverse conditions.

Features

Over sized air coil-higher COP and wider. Electrostatic coated air coil-corrosion protection. Titanium class A1 double coil shell-tube heat exchanger-higher COP. Electrical expansion valve-higher COP and wider working temperature range. Microprocessor controlled auto-charge defrost-high COP. Water proof display and keyboard for operation. Dual fan speed-low noise. Stainless steel cabinet on request. Compressor heater wider working temperature range. Quick connectors for easy and fast installation.

Fan

Large axial fans, with precision engineered blades are used to draw maximum ambient air and pass it on to the evaporator coils.

Refrigerant

We use the ecologically approved refrigerant R407-C, R410-A, R134-A, R22 depending on the clients requirement.

Thermostat

PROTEAM Europa heat and chill pumps are fitted with an electric thermostat with digital display for temperature and other functions.

Casting

Constructed in zinc-plated aluminium with PVC power coating to resist extreme outdoor weather conditions. Stainless steel is an option

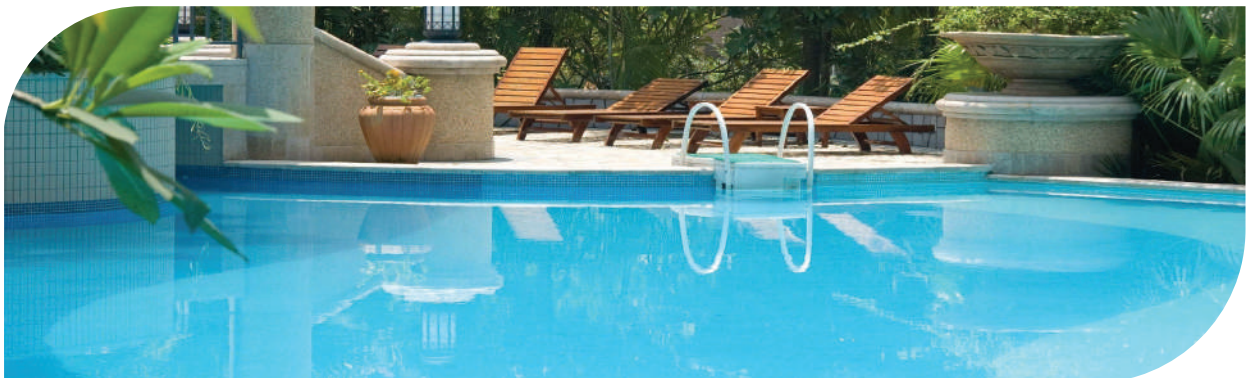

Pool Heating



Pool Heating



► Heat and Chill Pump

Technical Specification

Specification		Model				
		00500188	00500133	00500130	00500117	00500170
Heating Capacity	Kw	8.8	13	13	17	17
	BTU/hr	30000	44000	44000	58000	58000
Heating Power Input	kw	1.9	2.65	2.65	3.7	3.7
Cooling Capacity	kw	5.8	8.8	8.8	12	12
	BTU/hr	19720	30000	30000	41000	41000
Cooling Power Input	kw	2.1	2.85	2.85	3.9	3.9
Running Current	A	8.6/9.6	13.6/14.3	13.6/14.3	18.0/19.1	18.0/19.1
COP		4.9	4.9	4.9	4.8	4.8
Power Supply	V/PH/Hz	230/1/50	230/1/50	230/1/50	230/1/50	380/3/50
Compressor		1	1	1	1	1
Compressor Model		Rotary	Rotary	Rotary	Scroll	Scroll
Fan Quantity		1	1	1	1	1
Fan Input Power	W	150	150	200	150	200
Fan Rotate Speed	RPM	850	850	830	850	830
Fan Direction		Horizontal	Horizontal	Horizontal	Horizontal	Vertical
Noise	DB(A)	56	58	58	58	58
Water Connection	mm	50	50	50	50	50
Water Flow Volume	m3/hr	3	6	6	7.5	7.5
Water Pressure Drop (Max)	kPa	8	8	8	10	10
Unit Net Dimension (L/W/H)	mm	1010*420*650	1120*470*850	660*660*860	1120*700*920	660*660*860
Unit Net Weight	kg	77	90	86	100	100

Specification		Model				
		00500121	00500125	00500250	00500350	00500450
Heating Capacity	Kw	21	25	25	35	45
	BTU/hr	72000	86000	86000	120000	150000
Heating Power Input	kw	4.6	5	5	7.5	9.5
Cooling Capacity	kw	14.5	17.4	17.4	25	34
	BTU/hr	49500	59500	59500	86000	116000
Cooling Power Input	kw	5.2	5.8	5.8	8.4	9
Running Current	A	7.1/7.35	8.91/10.33	8.91/10.33	14.5/13.2	16.4/15.7
COP		4.8	4.9	4.9	4.8	4.9
Power Supply	V/PH/Hz	380/3/50	380/3/50	380/3/50	380/3/50	380/3/50
Compressor		1	1	1	2	2
Compressor Model		Scroll	Scroll	Scroll	Scroll	Scroll
Fan Quantity		1	1	1	2	2
Fan Input Power	W	200	200	200	200*2	200*2
Fan Rotate Speed	RPM	830	830	830	830	830
Fan Direction		Vertical	Horizontal	Vertical	Vertical	Vertical
Noise	dB(A)	59	59	59	60	61
Water Connection	mm	50	50	50	50	63
Water Flow	m3/hr	8	9	9	12	14
Water Pressure Drop (Max)	kPa	12	12	12	15	15
Unit Net Dimension (L/W/H)	mm	660*660*880	1450*750*920	660*660*880	1448*725*976	1450*730*1080
Unit Net Weight	kg	110	110	150	200	250

Data Sheet is based on capacities

Cooling - Ambient air temp: 46° C, Water Temp: 33°C

Heating - Ambient air temp: 16° C, Water Temp: 26°C

*Above data is subject to modification without notice for technical upgrade



Pool Heating



► Heat and Chill Pumps



Technical Specification

Specification	Model					
	00500550	00500900	00500105	00500160	00500210	
Heating Capacity	Kw	55	90	105	160	210
	BTU/hr	187000	306000	357000	550000	714000
Heating Power Input	kw	11	17.5	22.5	34.2	46.3
Cooling Capacity	kw	42	70	88	120	150
	BTU/hr	143000	238000	200000	410000	510000
Cooling Power Input	kw	10.3	17.8	24.7	41.6	56.2
Running Current	A	19.2/18	31.2/31.7	40.1/44.0	61.0/74.2	81.8/99.1
COP		4.9	4.7	4.5	4.7	4.5
Power Supply	V/PH/Hz	380/3/50	380/3/50	380/3/50	380/3/50	380/3/50
Compressor		2	3	4	4	4
Compressor Model		Scroll	Scroll	Scroll	Scroll	Scroll
Fan Quality		2	3	3	3	4
Fan Input Power	W	200*2	200*3	200*3	550*3	550*4
Fan Rotate Speed	RPM	830	830	830	870	920
Fan Direction		Vertical	Vertical	Vertical	Vertical	Vertical
Noise	dB(A)	61	62	62	65	67
Water Connection	mm	63	63	110	110	110
Water Flow	m3/hr	18	30	32	40	50
Water Pressure Drop (Max)	kPa	15	16	16	24	24
Unit Net Dimension (L/W/H)	mm	1450*730*1080	2230*927*1440	2303*1100*1961	2303*1100*2121	2303*1100*2121
Unit Net Weight	kg	265	370	695	950	1350

Pool Heating

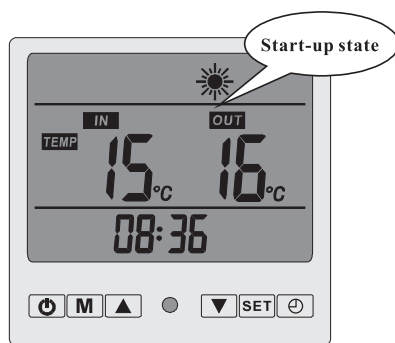

Display Board

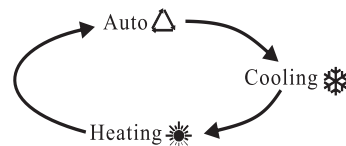

Control your pool temperature with mobile app



proteam-me.com | 359



Mobile App

Pool Heating



► Heat and Chill Pumps

Commercial Heat and Chill Pumps

Specification		Model				
		00500120	00500300	00500400	00500500	00500600
Heating capacity	KW	120	250	300	350	450
Heating power input	KW	23.2	43.3	60	65	105
Cooling capacity	KW	95	210	250	300	390
Cooling power input	KW	25.1	51.8	78	85	120
Running current	A	48.8/48.7	88/98	104.3/110	128.1/130	184.9/175
COP		5.1	5.7	5	5.3	4.2
Power supply	V/PH/Hz	50/3/380	50/3/380	50/3/380	50/3/38	50/3/380
Compressor model		Scroll	Scroll	Scroll	Scroll	Scroll
Fan direction		Vertical	Vertical	Vertical	Vertical	Vertical
Water connection	mm	90	110	140	140	140
Water flow	m ³ /hr	34.4	72	105	120	150
Dimension		1900 *1100 * 2300	2200*2000*2170	2200*2000*2170	2200*2000*2170	2600*2000*2200

Features

Proteam heat pump protection features | Refrigerant low pressure protection | Gas compressing side high temperature protection Compressor over current protection | Refrigerant high pressure protection | Gas compressing side temperature sensor protection

Data Sheet is based on capacities

Cooling - Ambient air temp 46° C, Water Temp: 33°C

Heating - Ambient air temp 16° C, Water Temp: 26°C



Pool Heating



Pool Heating



► Heat and Chill Pumps

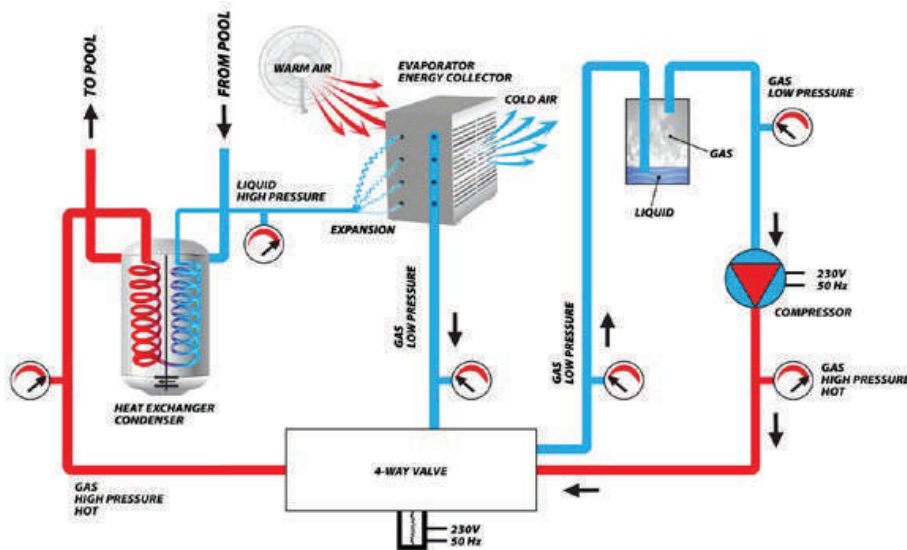

Working Diagram

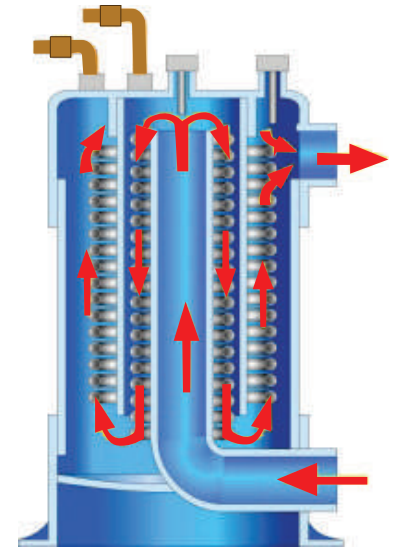

Heat Exchanger

Pool Heating

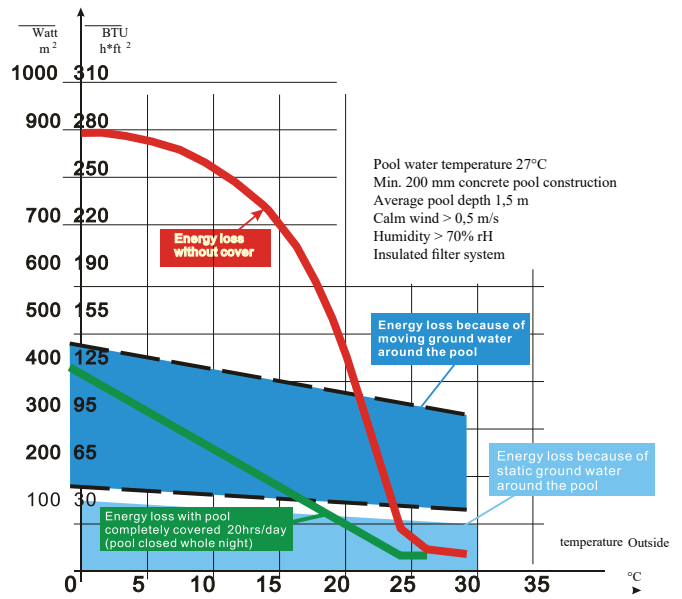

Energy Loss Graph



Pool Heating



► Heat and Chill Pumps



Installation

Location for installation of units is outdoor with free air movement for higher efficiency. Choose good place with ventilation. Keep proper space around the unit for installation and maintenance - see illustration. There must be drainage channel around the unit for condensing water. Parallel connection must be carried out if several units installed together.

Installation space for side discharge units

Model: 00500177, 00500125

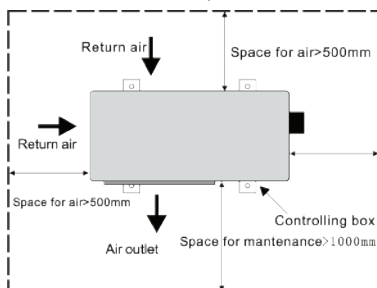

Installation space for side discharge units

Model: 00500350, 00500450, 00500900

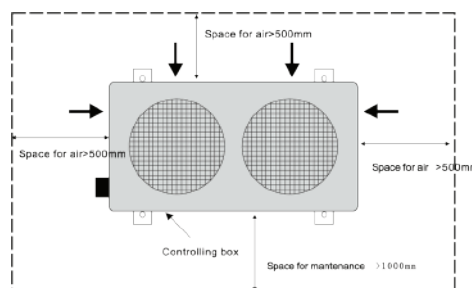

Pool Heating

Installation space for side discharge units

Model: 00500133, 00500170, 00500121, 00500250

There must be no obstacle on the top of these units as the air direction is vertical.

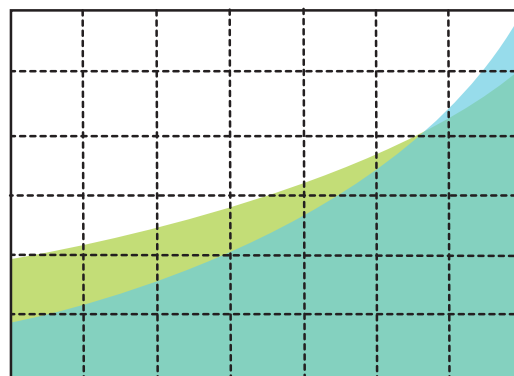
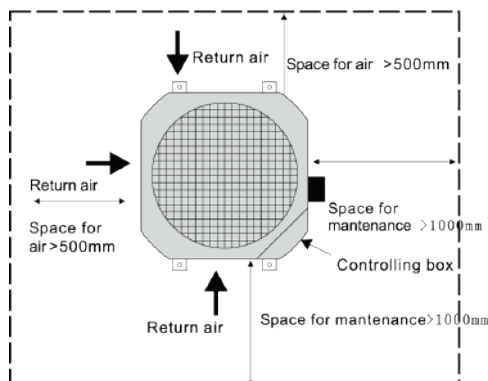

Noise Level

Power Input

Fan Speed



Pool Heating



► Unit Dimensions

Code	Size	A	B	C	D	E	F	G	H
00500133	mm	440	760	425	470	1120	400	80	685

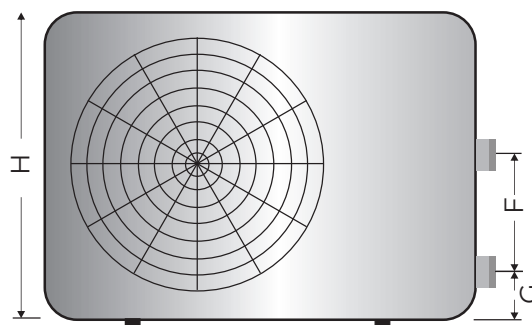
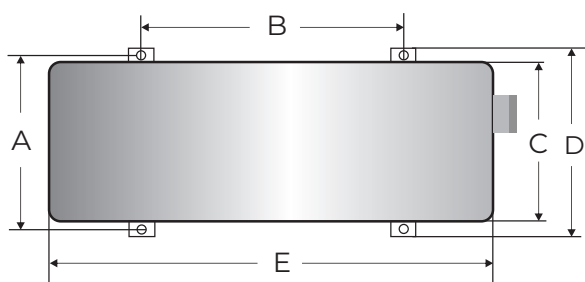

00500250

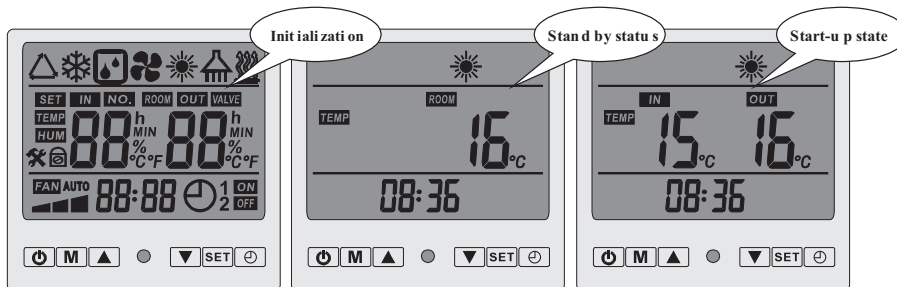
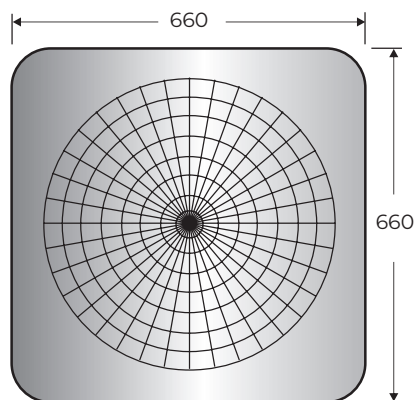
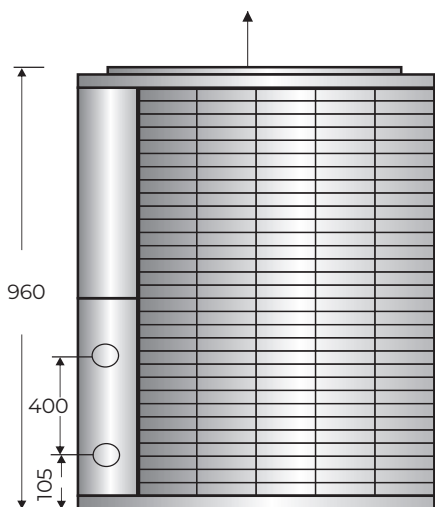

LED Display



Pool Heating



► Unit Dimensions

00500450 / 00500550

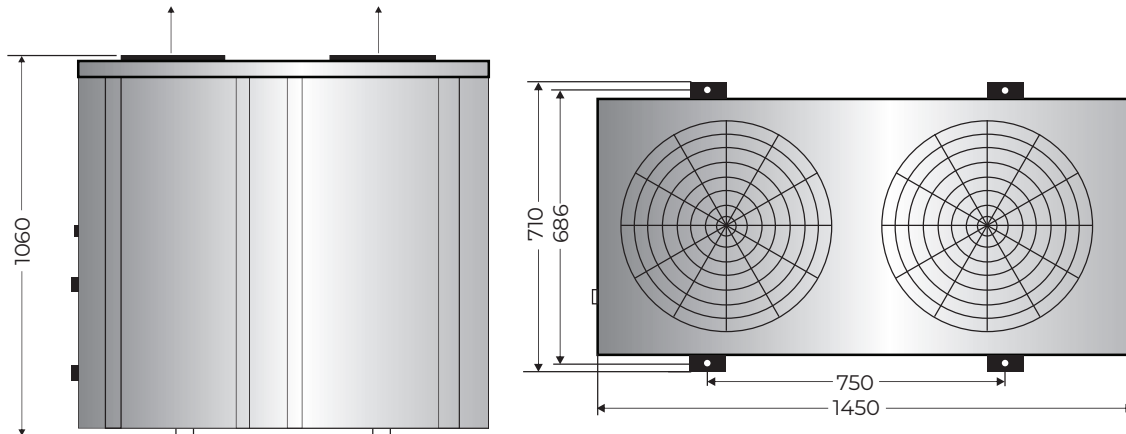

00500900

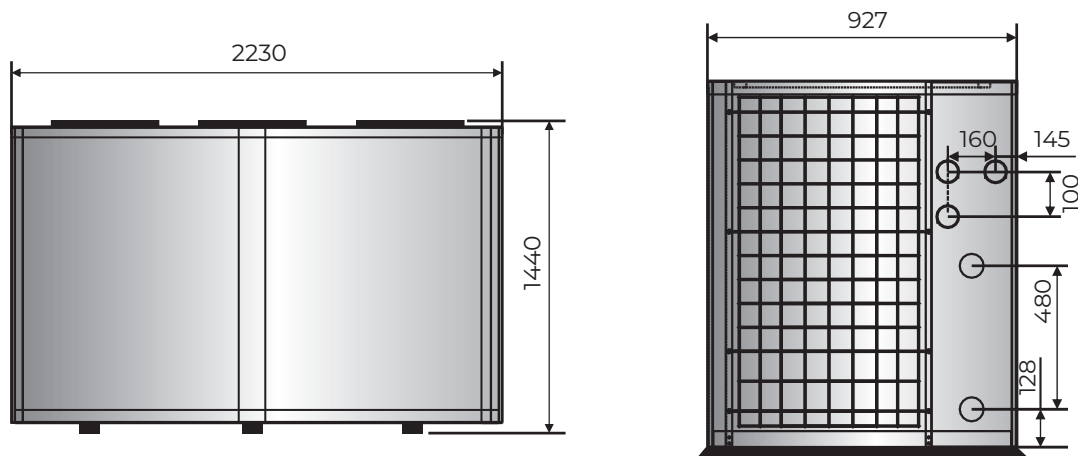

Pool Heating

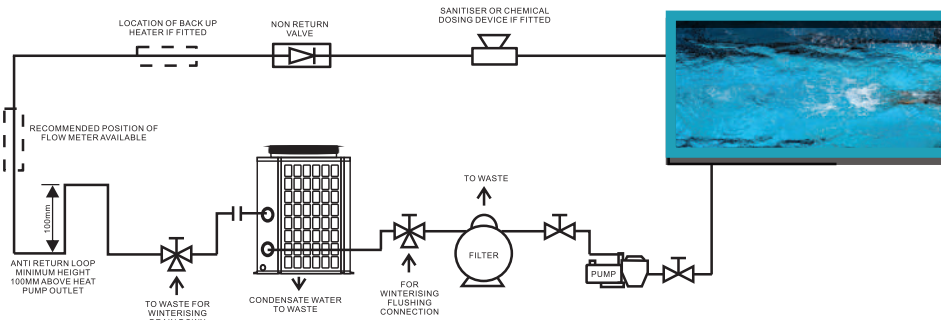

Recommended plumbing diagram



Pool Heating



► Unit Dimensions

00500105

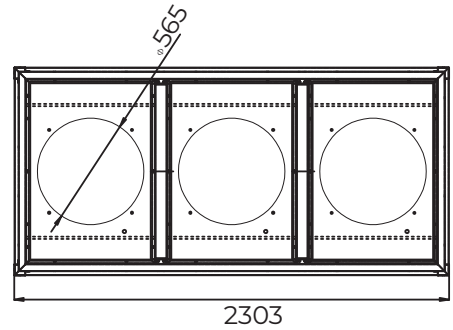
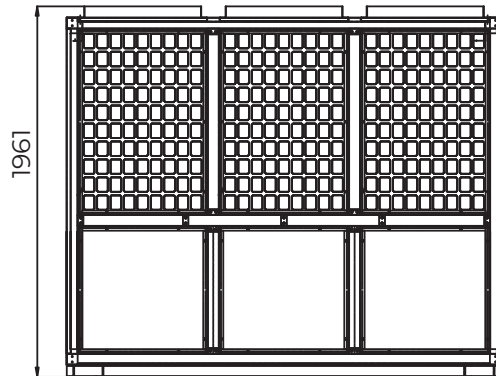
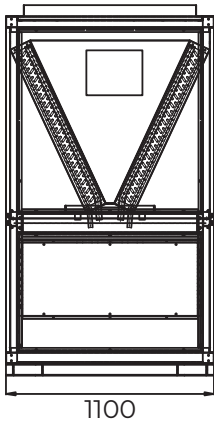

00500160 / 00500210

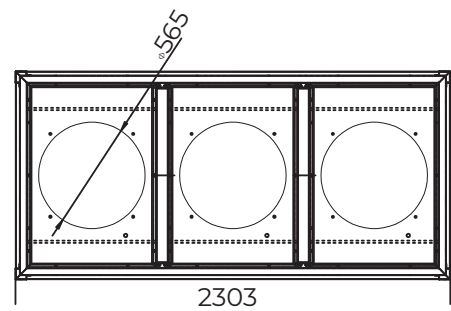
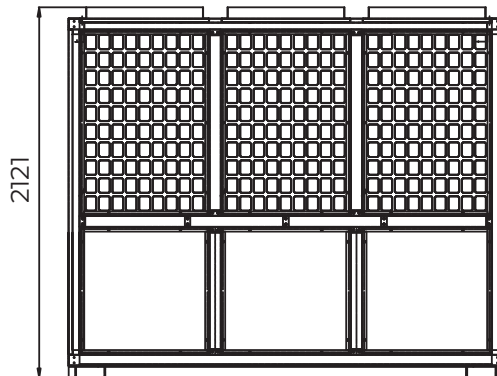
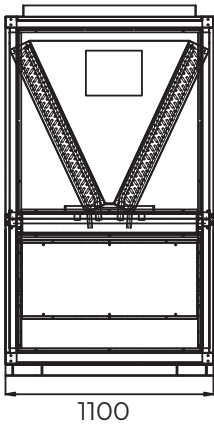

Pool Heating



Pool Heating



► Unit Dimensions

Commercial Unit with side fan

00500120 - 00500160

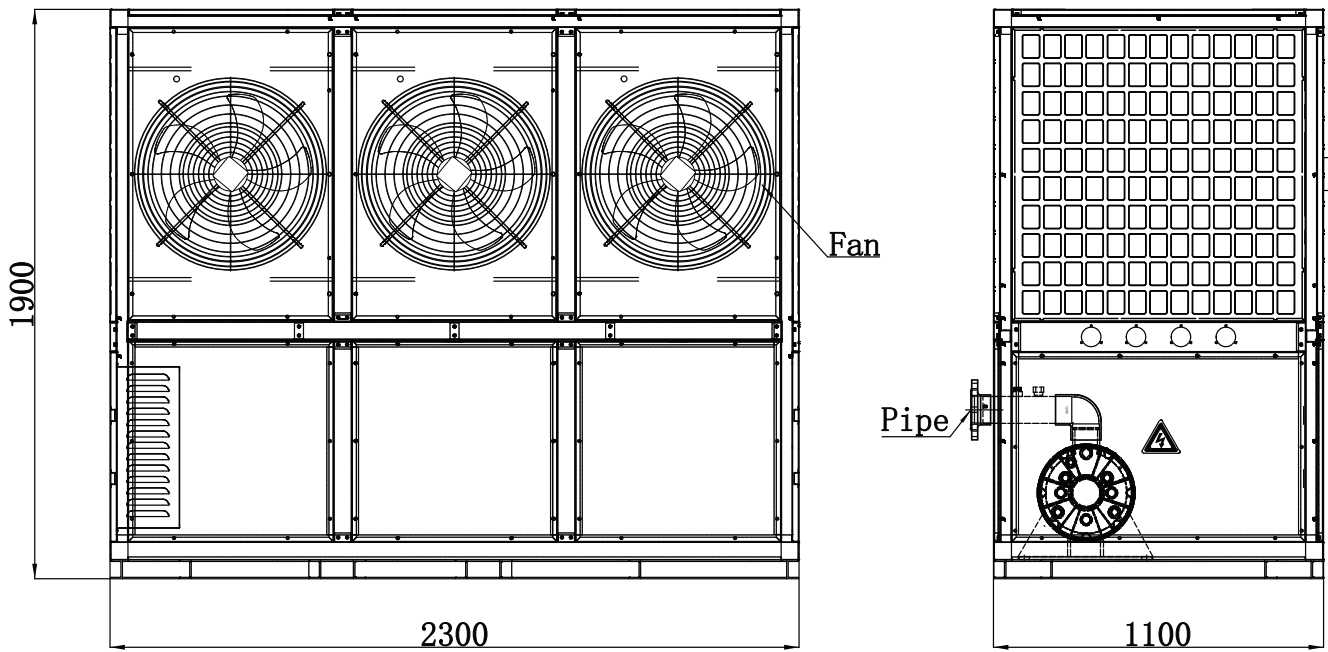

Pool Heating

00500120

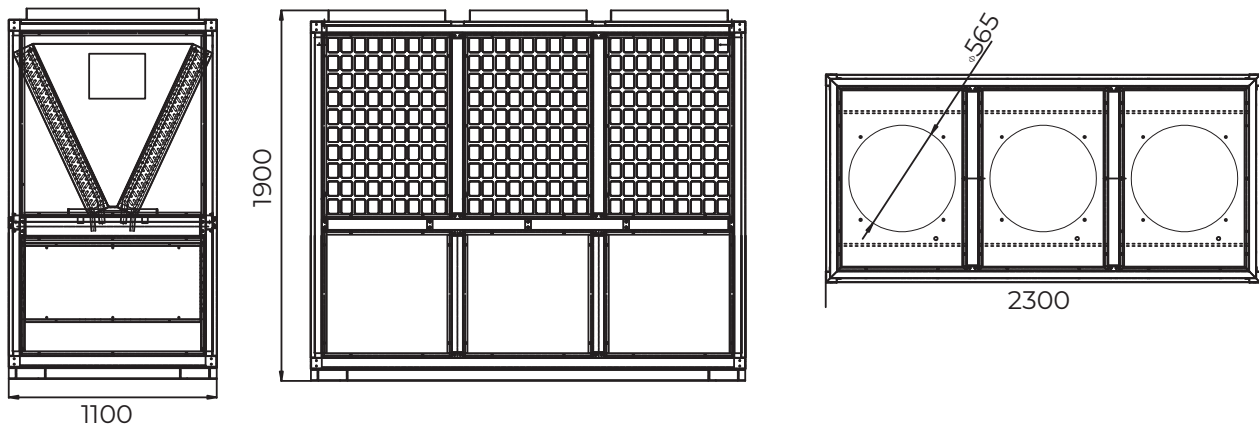

A close-up, low-angle shot of a woman's face floating in clear blue water. Her eyes are closed, and her hair is dark and wet. Water droplets are visible on her skin. The background is a soft, out-of-focus blue sky.

INVERTER HEAT AND CHILL PUMP

*Control your pool temperature
with mobile app*

proteam-me.com | 368



Pool Heating



► Inverter Heat and Chill Pump



Inverter Heat and Chill Pumps

PROTEAM Europa we are very aware of the need to balance the advantage associated with confort and enjoyment of your pool, with the potential impact that our product can have on the environment. We have recently also developed a complete range of variable -speed inverter units using the latest technological advances in the sector to maximize performance and minimize consumption. In consideration of this, proteam heat pumps have always been specifically designed to have higher COPs at lower temperature when maximum energy is needed. From 2019, all proteam heat pumps will be available with R32 gas, which is a more environmentally - friendly option compared to the traditional R410a gas (which will continue to be available).

Pool Heating

How Do Heat Pump Works

Heat pumps absorb and collect the energy available in the outside air , and transfer it to the pool water. The heat pump is connected to the pool filtration system , meaning that water is taken from the pool and circulated through the heat pump, where it is heated , before being returned to the pool. The unit itself has a fan that draws in outsides air and directs it over the surface of the epevaporator (which effectively an energy collector). The liquid refrigerant becomes a gas. The gas then passes through a compressor where it is compressed to form a very hot gas ,Which then passes through the heat exchanger (condenser). This is where the transfer of heat take place , as the hot gas releases heat to the cooler swimming pool water circulating through the coil . The pool water gradually becomes warmer and the hot gas cools back down to its liquid state as it flows through the condenser coil. It then passes through an expansion valve , the whole process is repeated.

Features

Full DC twin - rotary inverter compressor and brushless DC inverter motor with infinity variable speed. | Soft -starter (wide start -up voltage range) Intelligent controller | Wifi capability with dedicated user friendly app | 3 operating modes (silent /smart / boost) | Heatng and cooling function higher COP | Higher COP | Lower noise (inverter technology and insulated compressor) | Smart defrost | Very low working temperature up to -15°C | Environmentally friendly R32 or R410 gas.

Pool Heating



► Inverter Heat and Chill Pump



Soft - Started and Stable Operation

Proteam's full DC inverter technology ensures more stable running than traditional ON/OFF units allowing to maintain your pool water temperature at a more optimal level with reduced running cost. An incorporated soft starter ensures that your house's electricity supply is not affected when the unit starts up, as the current gradually increases after the unit is switched on and starts to operate. As a result, proteam inverter units are also able to operate in conditions where the main power supply is unstable (within an extended range of (180V-260V).

Three Operation mode for maximum Efficiency

BOOST MODE

20% - 100% capacity output
Fast heating
Late spring/early autumn In cooler climate

SMART MODE

20% - 80% capacity output
As standard
Spring to autumn in warmer climate

SILENT MODE

20%- 50% capacity output
Ideal for night use
Middle of summer in hot climate



Pool Heating



Pool Heating



► Inverter Heat and Chill Pump Specifications

Model	00600010	00600011	00600012	00600013	00600014
Advised pool volume (m ³) with insulating / isothermal cover	10~20	15~30	20~40	25~50	30~60
Performance					
Heating air 26°C/ water 26°C humidity 80% kw	1.6~5.3	1.6~7.2	1.9~9.2	2.7~10.9	3.4~14.3
Power input (kw)	0.13~0.88	0.13~1.19	0.13~1.28	0.18~1.74	0.23~2.32
COP	6.25~14.5	6.22~14.55	6.24~14.71	6.27~14.8	6.15~14.62
Heating air 15°C/ water 26°C humidity 70% kw	1.1~3.8	1.3~5.1	1.6~5.95	2.18~8.13	2.86~10.65
Power input (kw)	0.14~0.75	0.17~1.06	0.21~1.2	0.28~1.59	0.38~2.17
COP	5.1~7.9	4.8~7.8	5~7.7	4.9~7.8	4.9~7.6
Cooling air 35°C/ water 28°C humidity 80% kw	1.5~2.8	1.7~3.6	1.8~4.6	2.4~6.0	3.2~7.87
Power input (kw)	0.2~0.62	0.22~0.8	0.28~1.2	0.33~1.39	0.43~1.78
EER	4.51~7.55	4.48~7.53	4.47~7.46	4.32~7.34	4.41~7.42
Sound pressure level at 1m db(A)	38-47	39-48	39-48	40-49	43-52
Sound pressure level at 4m db(A)	27-35	29-37	29-37	30-38	31-38
Sound pressure level at 10m db(A)	19-27	20-28	20-28	21-28	21-29
Power supply	230V/50Hz/1 phase				
Operating air temperature	- 15°C ~ 43°C				
Max current A	5,35	7,24	6,53	8,4	9,6
Recommended water flow m ³ /h	2~3	2~3	3~5	4~6	5~7
Components					
Refrigerant	R32 or R410a				
Compressor type	DC twin rotary inverter				
Heat exchanger	Twisted coil ,titanium				
Fan direction	Horizontal				
Casing type	ABS				
Installation					
	Inlet/outlet unions G1-1/2"				
Unit dimensions(mm) L*W*H	860*330*668			986*356*668	
Shipping dimensions L*W*H	950*410*800			1080*435*800	
Net /Gross weight kg	35/42	38/45	40/48	44/54	46/56

*Above data is subject to modification without notice for technical upgrade

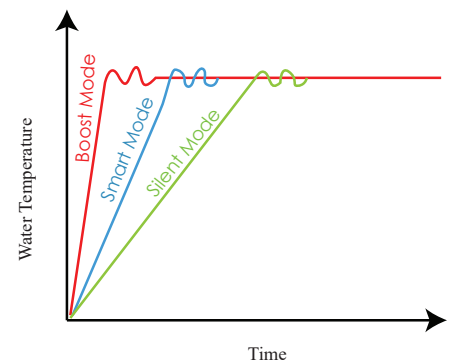
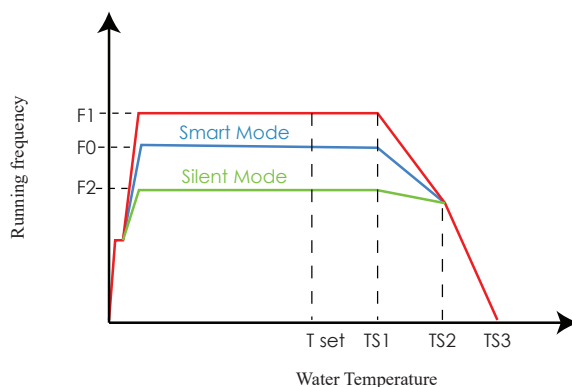

Pool Heating



► Residential & Commercial Inverter Heat Chill Pump



Inverter Heat and chill pump

PROTEAM Europa we are very aware of the need to balance the advantage associated with confort and enjoyment of your pool, with the potential impact that our product can have on the environment. We have recently also developed a complete range of variable -speed inverter units using the latest technological advances in the sector , to maximize performance and minimize consumption. In consideration of this, proteam heat pumps have always been specifically designed to have higher COPs at lower temperature when maximum energy is needed. From 2019, all proteam heat pumps will be available with R32 gas, which is a more environmentally - friendly option compared to the traditional R410a gas (which will continue to be available).

Pool Heating

Control your pool temperature with mobile app

User Interface

- 1 Current pool temperature
- 2 Setting temperature
- 3 Current operating mode
- 4 Switch the heat pump on / off
- 5 Change the temperature
- 6 Change operating mode
- 7 Setting the operating ranges



Mobile App



Pool Heating



► Residential & Commercial Inverter Heat Chill Pump

Technical Specification

Code	00600015	00600016	00600017	00600018	00600019
Advised pool volume (m ³) with insulating / isothermal cover	35~70	40~80	65~110	70~120	80~150
Performance					
Heating air 15°C/ water 26°C humidity 80% kw	4.3~17.4	4.8~21.2	6.2~25.1	6.6~29	7.7~31.7
Power input (kw)	0.29~2.85	0.33~3.38	0.4~3.8	0.46~4.42	0.54~5.21
COP	6.0~14.5	6.36~14.55	6.2~14.52	6.1~14.54	6.11~14.6
Heating air 15°C/ water 26°C humidity 80% kw	3.49~13	3.76~15.7	5.15~18.52	5.43~21.28	6.34~23.68
Power input (kw)	0.47~2.64	0.48~2.75	0.61~3.6	0.73~4.1	0.87~4.8
COP	4.85~7.44	5.1~7.52	4.91~7.53	4.95~7.51	4.9~7.6
Cooling air 35°C/ water 28°C humidity 80% kw	3.9~9.6	4.3~11.5	5.8~13.9	6.2~16	7.2~17.5
Power input (kw)	0.51~2.3	0.57~2.62	0.73~3.1	0.82~3.48	0.97~4.17
EER	4.24~7.4	4.38~7.48	4.15~7.22	4.29~7.54	4.21~7.44
Sound pressure level at 1m db(A)	45-53	45-54	48-56	49-56	50-57
Sound pressure level at 4m db(A)	33-41	33-41	36-42	37-45	38-47
Sound pressure level at 10m db(A)	23-32	24-32	25-34	27-37	27-38
Power supply	V/PH/Hz				
Operating air temperature	- 15°C ~ 43°C				
Max current A	13,77	14,3	18,36	21,35	25,2
Recommended water flow m ³ /H	6~8	7~9	8~11	9~12	12~15
Components					
Refrigerant	R32 or R410a				
Compressor type	DC twin rotary inverter				
Heat exchanger	Twisted coil ,titanium				
Fan direction	Horizontal				
Casing type	ABS				
Installation					
Inlet/outlet unions G1-1/2"					
Unit dimensions(mm) L*W*H	1076*426*720			1176*451*822	
Shipping dimensions L*W*H	1161*490*855			1261*515*957	
Net /Gross weight kg	56/66	67/80	72/85	98/116	

Pool Heating



Pool Heating



► Residential & Commercial Inverter Heat Chill Pump

Heating and Cooling Performance

Code		00660100	00660200	00660300	00660400	00660500
Heating Capacity at Air 28°C, Water 28°C, humidity 80%						
Heating Capacity Max-Min speed	Kw	30.11 ~ 6.81	42.15 ~ 9.56	70 ~ 16.5	103 ~ 24.8	136 ~ 32.4
Power consumption Max- Min speed	Kw	4.32 ~ 0.42	6.04 ~ 0.59	10.03 ~ 1.02	14.8 ~ 1.54	19.46 ~ 2.01
COP		16.14 ~ 6.97	16.15 ~ 6.98	16.11 ~ 6.98	16.09 ~ 6.96	16.15 ~ 6.99
Heating Capacity at Air 15°C, Water 26°C, humidity 70%						
Heating Capacity Max-Min speed	Kw	21.43 ~ 4.88	32.68 ~ 7.43	51 ~ 12.1	76 ~ 18.0	101 ~ 23.09
Power consumption Max- Min speed	Kw	4.30 ~ 0.64	6.55 ~ 0.97	10.24 - 1.6	15.29 ~ 2.42	20.24 ~ 3.15
COP (Max- Min Speed)		7.63 ~ 4.98	7.65 ~ 4.99	7.56 - 4.98	7.55 ~ 4.97	7.58 ~ 4.99
Cooling Capacity at Air 43°C, Water 32°C						
Cooling Capacity Max-Min speed	Kw	15.56 ~ 4.14	23.15 ~ 5.88	38 - 9.1	58 ~ 14.1	76 ~ 18.5
Power consumption	Kw	4.23 ~ 0.62	6.34 ~ 0.88	10.14 - 1.36	15.89 ~ 2.11	20.65 ~ 2.74

Technical Features

Electric Power supply	V/Ph/Hz	380/3/50 or 60Hz	380/3/50 or 60Hz	380/3/50 or 60Hz	380/3/50 or 60Hz	380/3/50 or 60Hz
Operating Current	A	7.7	11.6	24	34	46
Operating Power Input	KW	4.3	6.55	15.1	22.5	30
Max Current (A)	A	11	17	27	39	54
EER		6.68 - 3.68	6.67 - 3.65	6.69 - 3.56	6.68 - 3.65	6.74 - 3.68
Refrigerant		R410a/R32	R410a/R32	R410a/R32	R410a/R32	R410a/R32
Compressor		Inverter	Inverter	Inverter	Inverter	Inverter
Heat Exchanger		Titanium	Titanium	Titanium	Titanium	Titanium
Expansion Valve		Electronic	Electronic	Electronic	Electronic	Electronic
Air Flow Direction		Vertical	Vertical	Vertical	Vertical	Vertical
Water Flow Volume	m3/hr	9	14	20	30	40
Working temperature	0°C	-15~52	-15~52	-15~43	-15~43	-15~43
Acoustic pressure level at 1m	dB	≤51	≤52	≤70	≤72	≤74
Acoustic pressure level at 4m	dB	≤41	≤43	≤58	≤60	≤62
Acoustic pressure level at 10m	dB	≤32	≤34	≤48	≤49	≤51
Fan Air flow	m3/hr	5000	6000	10000	12000	24000
Hydrolic connection	mm	50	50	63	63	75
Heating Temp Range	0°C	15~40	15~40	15~40	15~40	15~40
Cooling Temp Range	0°C	8~28	8~28	8~28	8~28	8~28
No of Compressor		1	1	1	2	2

Pool Heating

Dimention and Weight

Dimensions L*W*H	mm	740*720*940	720*720*940	1317*1077*1865	1317*1077*1866	2224*1077*2177
Weight	Kg	95	125	380	450	760

The technical specification of our heat pumps are provided for information purpose only.
We reserve the right to make changes without prior notice.



Pool Heating



► Residential & Commercial Inverter Heat Chill Pump

Display controller

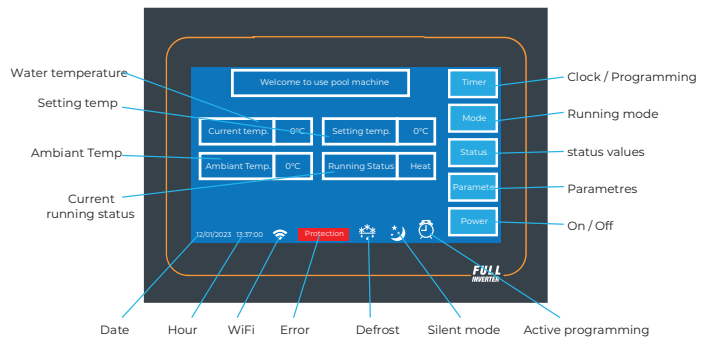

Heating Mode



Cooling Mode



Silence Mode



Defrost mode

Pool Heating

By-Pass installation of a heat pump

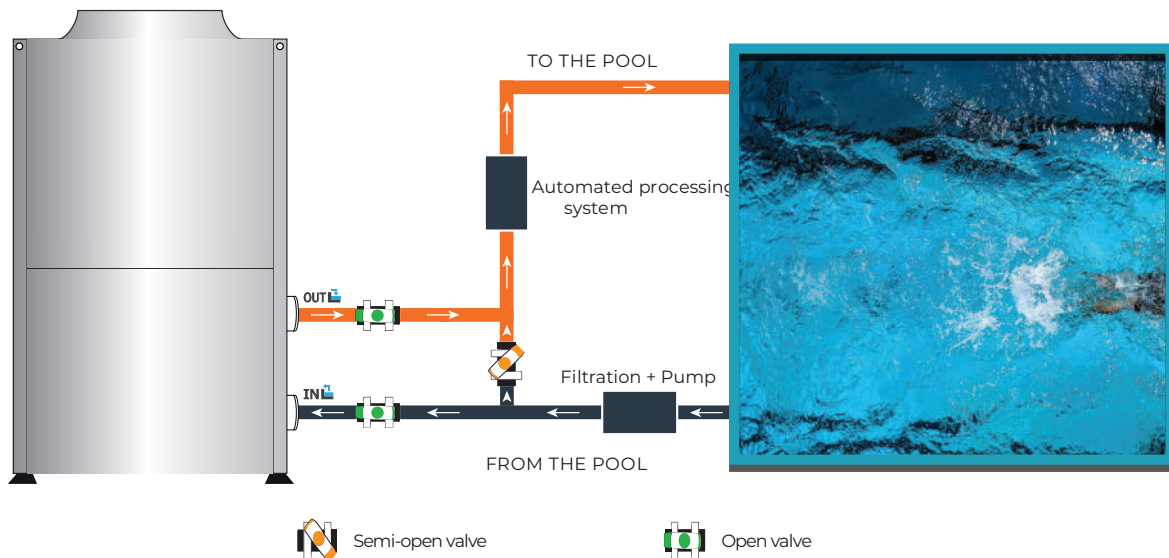

Pool Heating



► Residential & Commercial Inverter Heat Chill Pump

Dimensions

00660300 / 00660400 / 00660500

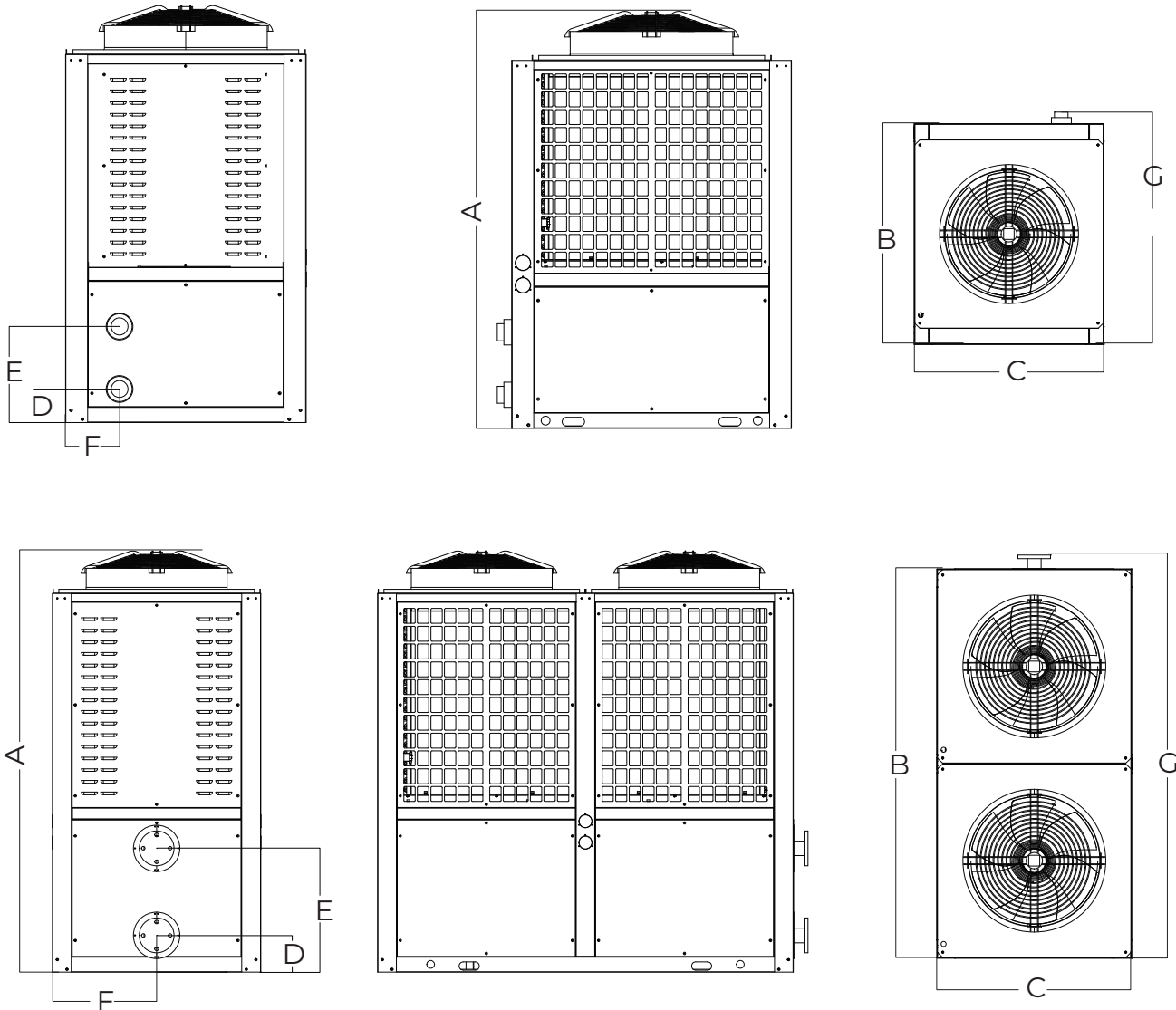

Pool Heating

Dimensions in mm

Model	00660300 / 00660400	00660500
A	1865	2176
B	1252	2148
C	1076	1076
D	150	190
E	430	640
F	242	242
G	1317	2224



Pool Heating



► Residential & Commercial Inverter Heat Chill Pump

Display Controller

00660100 / 00660200

Unit Dimension

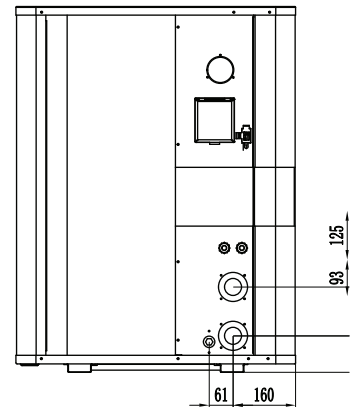
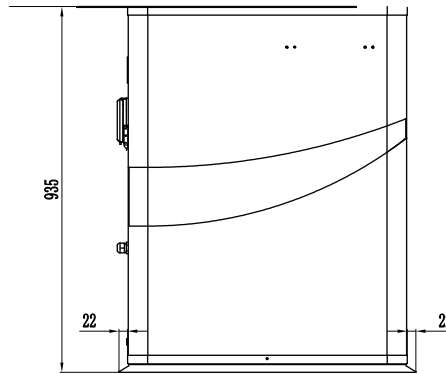
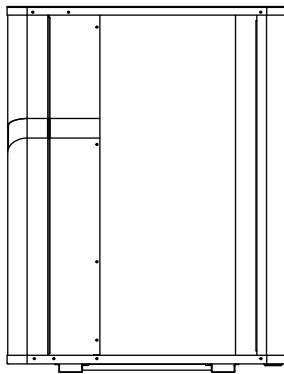
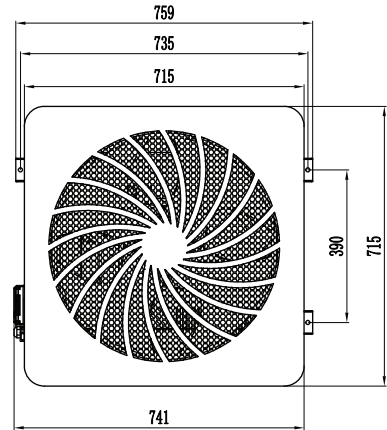
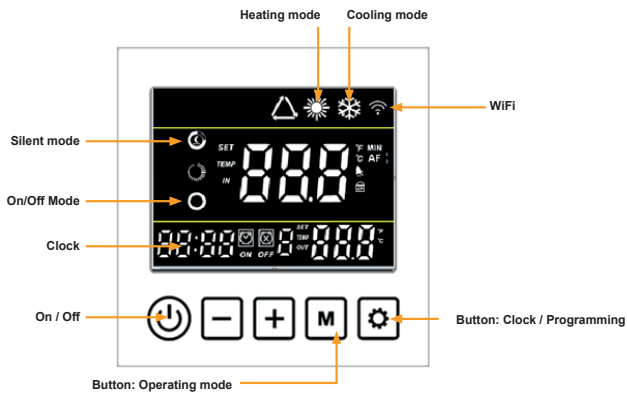

Pool Heating

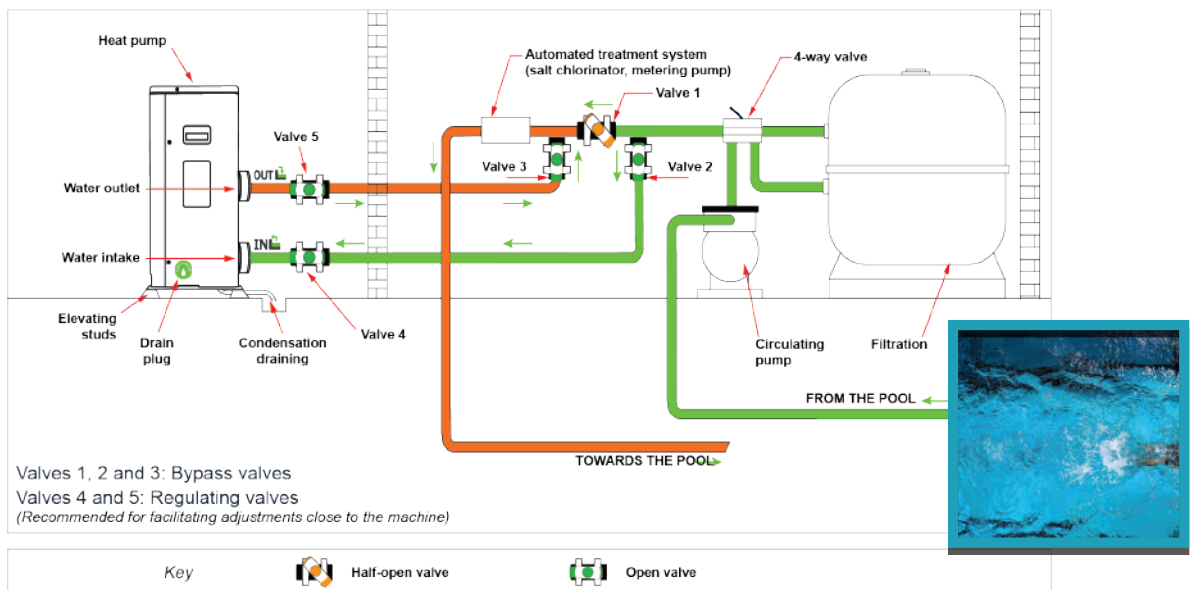

Pool Heating



► Inverter Variable Speed Pool Heat Pump



Code	00600020	00600021	00600022	00600023	00600024	00600025
Advised pool volume (m3)	20-45	25-55	35-70	45-90	60-115	85-170
Operating Air temperature(°C)	15 - 43					
Performance condition Air 27°C/water 26°C/Humidity 80%						
Heating capacity(KW)	2-8	2-11	3-16	4-19	5-23	6-27
Heating Capacity(BTU)	7311-30550	9695-40750	12820-57750	15645-66255	19375-82275	22775-96200
Consumed power (kw)	0.17-1.7	0.22-2.13	0.4-3.12	0.38-3.95	0.47-4.7	0.55-5.58
COP	13.45-5.64	13.58-5.67	12.58-5.64	12.44-4.96	12.40-5.05	12.42-5.09
Performance condition Air 15°C/water 26°C/Humidity 70%						
Heating capacity(KW)	1.76-7.5	2.26-9.8	2.93-12.5	3.85-15.5	4.69-20	5.47-23.5
Heating Capacity(BTU)	5951-25161	7651-32982	9930-42162	13057-52361	15915-67665	18565-77922
Consumed power (kw)	0.26-1.7	0.33-2.09	0.45-2.87	0.7-3.82	0.73-4.75	0.84-5.50
COP	7-4.65	7.04-4.67	6.65-4.35	6.5-4.05	6.6-4.4	6.59-4.25
Performance condition Air 10°C/water 26°C/Humidity 64%						
Heating capacity(KW)	1.45-6.3	1.89-9	2.6-10.8	3.39-14.5	4.3-17.9	5-20.9
Heating Capacity(BTU)	4830-20745	6395-27250	8550-36390	11495-48965	14285-60525	16665-70722
Consumed power (kw)	0.26-1.6	0.34-1.96	0.46-2.68	0.63-3.64	0.76-4.5	0.88-5.2
COP	5.69-4.08	5.8-4.2	5.57-4.06	5.46-3.99	5.7-4.04	5.64-4.09
Power supply	220-240V /1PH			380-400V-/3PH		
Casing type	ABS	ABS	ABS	ABS	ABS	ABS
Fan Quantity	1	1	1	1	2	2
Fan speed	400-800	400-800	500-750	500-900	400-800	400-900
Sound pressure 1m dB(A)	40-50	42-52	44-53	45-56	46-57	48-58
Silence mode 1m dB(A)	40	42	44	45	46	48
Sound pressure 10m dB(A)	20-30	22-32	24-33	25-36	26-37	28-38
Silence pressure 10m dB(A)	20	22	24	25	26	28
Water Connection (mm)	50	50	50	50	50	50
Water flow volume(m3/h)	3.5	4.7	5.4	6.7	8.6	10
Water pressure Drop (max)Kpa	4	4.5	5	6	11	15
Net dimension(L/W/H)(mm)	955*405*625		1115*485*875		1170*475*1280	
Refrigerant gas	R410A/R32				R32	

Pool Heating

*Above data is subject to modification without notice for technical upgrade



Pool Heating



► Inverter Variable Speed Pool Heat Pump

Proteam Europa full inverter technology on commercial pool heat pump. it allows the heat pump to reach high COP of 16 air 27°C/Water 26°C/Humid.80%. With variable running speed basing on actual heating or cooling requirments, the series helps to save big running cost for commercial occasions including aqua park, hotels,gyms and so on.

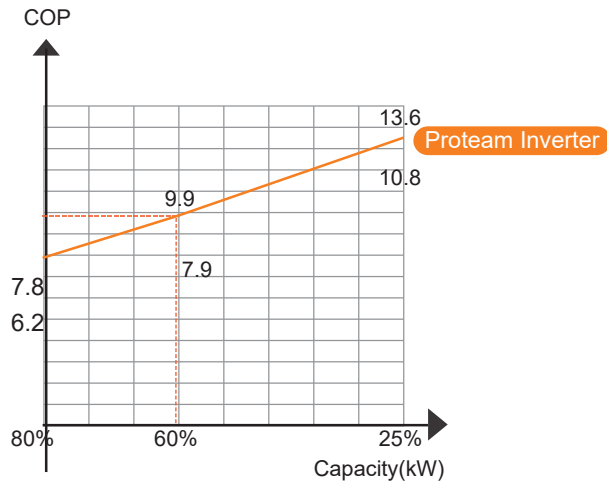

Performance condition air 27°C
Water 26°C Humidity 80°C

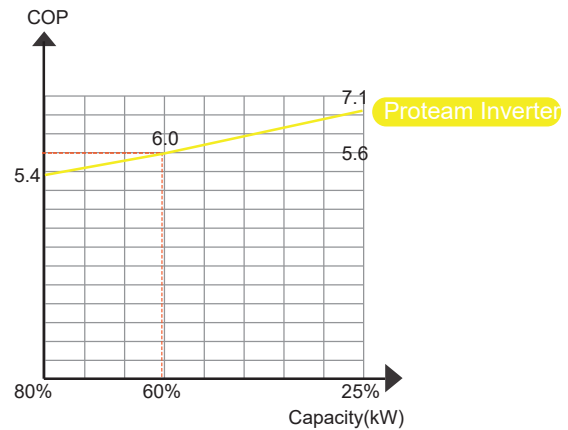

Performance condition air 15°C
Water 26°C Humidity 70°C

Pool Heating



Pool Heating



► Heat Pump Specification Water to Water Series - Indoor Installation

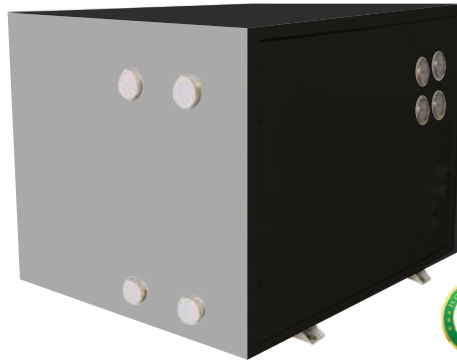

Specification		PRHP050	PRHP060	PRHP070	PRHP0850	PRHP2000
Refrigerant		R410a	R410a	R410a	R410A	R410A
Heating Capacity	kw	15.5	17.5	20.6	25.1	35.1
Power Input	w	3120	3680	4285	5190	7280
C.O.P		4.97	4.76	4.81	4.84	4.82
Power supply	V/Ph/Hz	230/1/50	230/1/50	380/3/50	380/3/50	380/3/50
Amp (heating)	Amp	14.5	17.4	8.5	9.8	14
Circuit breaker	Amp	30	30	16	30	30
Compressor	Type	Scroll	Scroll	Scroll	Scroll	Scroll
Heat Exchanger	P/T	Titanium	Titanium	Titanium	Titanium	Titanium
Noise	db(A)	≤54	≤54	≤58	≤60	≤62
Pressure Drop	mpa	≤0.4	≤0.4	≤0.4	≤0.4	≤0.4
Water flow	m3/h	2~5	3~6	4~7	5~8	6~12
Water connection	inch/cm	2.0/5.0	2.0/5.0	2.0/5.0	2.0/5.0	2.0/5.0
Weight	kg	88	94	118	146	166
Dimension	mm	950*400*620	950*400*620	950*400*620	1060*440*760	1060*440*760

Pool Heating

Specification		PRHP1700	PRHP2500	PRHP3300	PRHP5000	PRHP6000
Refrigerant		R410a	R410a	R410a	R410a	R410a
Heating Capacity	kw	49.9	75.2	90.7	151.2	175.8
Power Input	kw	10300	15600	18600	31100	35900
C.O.P		4.84	4.82	4.88	4.86	4.90
Power supply	V/Ph/Hz	380/3/50	380/3/50	380/3/50	380/3/50	380/3/50
Amp (heating)	Amp	20.1	30.3	36.5	60.3	69.6
Circuit breaker	Amp	30	50	75	100	100
Compressor	Type	Scroll	Scroll	Scroll	Scroll	Scroll
Heat Exchanger	Type	Titanium	Titanium	Titanium	Titanium	Titanium
Noise	db(A)	≤64	≤66	≤70	≤75	≤75
Pressure Drop	m3/h	6 ~ 10	6~ 12	8~16	15~30	18~36
Water flow	mpa	≤0.4	≤0.4	≤0.4	≤0.4	≤0.4
Water connection	inch/cm	2.0/5.01	2.5/6.35	2.0/5.01	4/10.16	4/10.16
Weight	kg	192	385	780	1250	1480
Dimension	cm	1250*560*1080	1250*560*1080	1350*600*1080	1600*660*1080	1600*660*1080

*Above data is subject to modification without notice for technical upgrade



Pool Heating



► Heat Pump Specification Water to water Series Indoor Installation

Specification		PRHP1300	PRHP1375	PRHP1465	PRHP1600	PRHP1850
Refrigerant		R410a	R410a	R410a	R410a	R410a
Heating Capacity	kw	299.3	375.5	465.2	790.1	850.6
Power Input	kw	61.3	76.8	95.1	161.2	166.6
C.O.P		4882.54	4889.32	4891.69	4901.36	5105.64
Power supply	V/Ph/Hz	380/3/50	380/3/50	380/3/50	380/3/50	380/3/50
Amp (heating)	Amp	119.1	148.9	184.4	313.2	322.9
Circuit breaker	Amp	170	214	265	450	465
Compressor	Type	Scroll	Scroll	Scroll	Scroll	Scroll
Heat Exchanger	Type	Titanium	Titanium	Titanium	Titanium	Titanium
Noise	db(A)	≤80	≤85	≤88	≤92	≤95
Pressure Drop	m3/h	31~ 62	39~77	48~95	82~162	90~178
Water flow	mpa	≤0.4	≤0.4	≤0.4	≤0.4	≤0.4
Water connection	inch/cm	4/10.16	4/10.16	4/10.16	4/10.16	4/10.16

*Above data is subject to modification without notice for technical upgrade

Proteam water to water heat pump refrigerant Diagram

Pool Heating

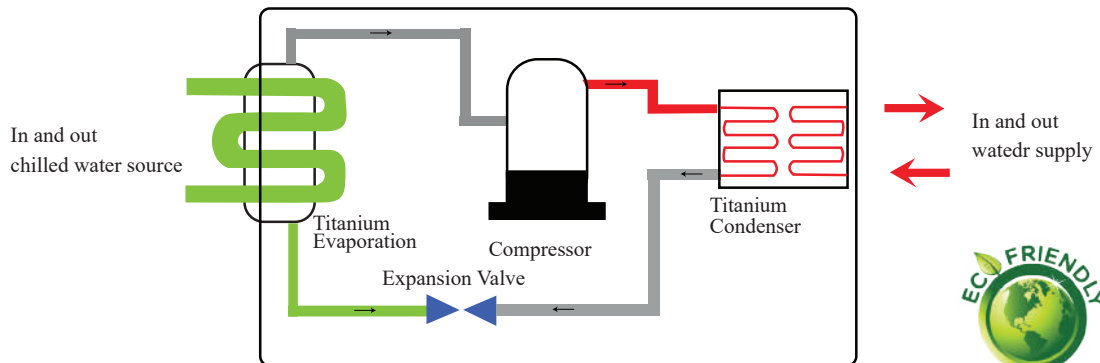

PROTEAM WATER TO WATER HEAT PUMP HEATING DIAGRAM

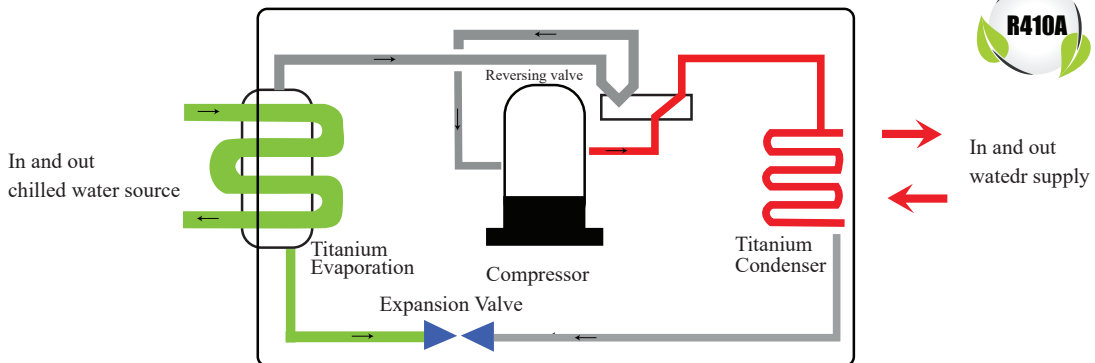

Pool Heating



► Residential Heat Pump with Water Tank



Proteam Europa all in one HOT MAGIC heat pump water heater is a very smart design to provide domestic hot water for the house. With all in one type and water tank inside, it is very easy for installation and convenient for users. The Heat Pumps water heater are widely used in family and some small public places like hotels, restaur-

Variable Speed Fan

The working units can adjust the fan speed at any time to reduce the input power, meanwhile, reduce noise to achieve energy saving and silent running.

Expansion Valve

The units automatically adjust the refrigerant flow rate, ensuring that the units operate with high efficiency in all weather conditions.

Compressor

Compressor with precise energy stage setting ensures that the working unit to achieve the desired energy saving effect.

COP

COP of 4.2 at working condition of 20oC/15oC the proteam heat pump has high efficiency for hot water supply.

Tank inside with long lifespan

The quality enamel tank make sure the life time for the tank and keep it health for hot water.

Heat Exchanger

The coil outside of the inner tank, separate the Refrigerant with the tank water to keep it safety for the water quality. The quality coil heat exchanger make sure the high efficient for the heat pump water heater.

Pool Heating



Pool Heating



► All in one HOT MAGIC Heat Pump water heater Square / Round Tank



Model	00500165	00500170	00500175	00500180
Heating Capacity at Air 20°C/15°C, Water Temperature from 15°C to 55°C				
Heating Capacity kW	2	2	2.2	2.2
Power Input kW	0.51	0.51	0.53	0.53
COP	3.92	3.92	4.16	4.16
Max Power Input kW	2.4	2.4	3000	3000
Rated Current (A)	2.6	2.6	2.9	2.9
Max Current (A)	12.2	12.2	15	15
Power Supply	220v/1/50Hz	220v/1/50Hz	220v/50Hz	220v/50Hz
Backup Electric Heater (W)	1500	1500	2000	2000
Refrigerant	R410A	R410A	R134A	R134A
Net Dimensions (mm)	500x500x1628	500x500x1628	620x1750	620x1950
Package Dimension (mm)	680x680x1805	680x680x1805	700x700x1930	700x700x2130
Net Weight (kg)	75	93	105	130
Noise (dB)	48	48	48	48
Water tank volume(L)	120	180	200	300
Working temperature °C	-7~43	-7~43	-7~43	-7~43

Pool Heating





Pool
Heating

High Temperature Water Heat Pump



Pool Heating



► High Temperature Water Heat Pump



Model	00500100	00500110	00500115	00500130	00500175
Power Supply	220V/50Hz	380V/3/50Hz	380V/3/50Hz	380V/3/50Hz	380V/3/50Hz
Heating Capacity at Air 20°C/15°C, Water Temperature from 15°C to 60°C					
Heating Capacity kW	10	17	25	45	55
Power Input kW	2.83	3.56	5	10	12.7
COP	4.5	4.23	4.3	4.5	4.4
Max Power Input kW	3.36	4.52	7	13.5	16.8
Max Current (A)	15.3	21	22	33.5	31.5
Refrigerant	R410a	R410a	R410a	R410a	R410a
Rated Hot Water L/h	260	320	450	900	1200
Compressor	GMCC	Copeland Scroll	Copeland Scroll	Copeland Scroll	Copeland Scroll
Expansion Valve	Electronic	Electronic	Electronic	Electronic	Electronic
Air Flow Direction	Horizontal	Horizontal	Vertical	Vertical	Vertical
Water Flow Volume (m ³ /h)	2.8	4.5	5	8	10
Dimensions (L*W*H) mm	986×420×798	986×420×798	765×691×1055	1416×752×1055	995×990×1785
Working Amb temp °C	-15~43	-15~43	-15~43	-15~43	-15~43
Noise (dB)	≤53	≤53	≤60	≤65	≤65
Net Weight (kg)	75	85	160	259	305
Connection (mm)	20	20	25	32	40
Water Pressure drop (kPa)	46	45	50	50	55

Pool Heating

Proteam Europa specially designed high temperature water heat pumps for residential, hotel, Hospital and school projects. Maximum water temperature 15-60°C.

Variable Speed Fan

The working unit can be adjust fan speed at any time to reduce the input power meanwhile a reduce noise to achive energy saving and silent running.

Expansion Valve

The unit automatically adjust the refrigerant flow rate ensure that the unit operate with high efficiency in all weather condition

Heat Exchanger

This is made of double spiraled of the heat exchanger increase the surface area that comes in contact with the pool water and also drastically reduces scaling.

Compressor

We use the reliable COPELAND scroll compressor. The simple design is with very few moving parts that enable it to operate at lower sound and vibration levels than reciprocating compressors.



Pool Heating



► High Temperature Water Heat Pump

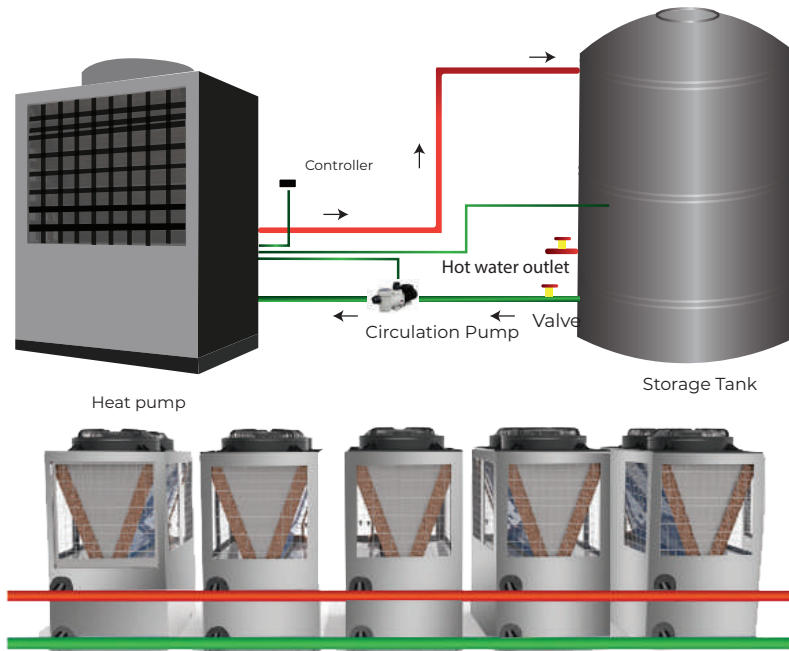

Model	00500140	00500145	00500150
Power Supply	380V/50Hz		
Heating Capacity at Air 20°C/15°C, Water Temperature from 15°C to 55°C			
Heating Capacity kW	80	125	200
Power Input kW	20.5	27.1	44.5
COP	4.42	4.45	5.5
Max Power Input kW	27.4	36.5	66
Max Current (A)	51.2	68.1	110
Refrigerant	R410a	R410a	R410a
Rated Hot water L/h	2000	2600	4000
Compressor	Copeland Scroll	Copeland Scroll	Copeland Scroll
Expansion Valve	Electronic	Electronic	Electronic
Air Flow Direction	Vertical	Vertical	Vertical
Water Flow Volume (m ³ /h)	16	18	33
Dimensions (L*W*H) mm	2150×1075×2175	2150×1075×2175	2250×2150×2177
Working temperature °C	-15~43	-15~43	-15~43
Noise (dB)	≤70	≤71	≤77
Net Weight (kg)	650	800	1600
Connection (mm)	50	50	80
Water Pressure drop (kPa)	55	55	58

Pool Heating

Centralized Control Panel

Proteam Heat Pump come equipped with centralized control that make temperature adjustment and failure review easier. By incorporating the master-slave control into the design, the whole units can work together with higher efficiency without interfered by any failure of the salve unit during operation.

Features

Adopt R410A refrigent environmental friendly | Higher water temperature output up to 60 degree C | Adopt tube in tube heat exchanger and circulation Heating method higher COP | Defrost automatically intelligent and fast | High pressure protetin function | With MODBUS communication | Full automatically operation

